

Anderson Mex Pourers

The Semi-Fixed Solution to Bund Protection

- Semi-fixed units
- Suited to applications requiring large volumes of free flowing foam
- Efficient and cost effective
- Compact and robust



Bulk Storage Tank bund fires, because of their large surface area, are notoriously difficult to control and extinguish. Spillages in these banded areas are common and have caused several major tank fires.

Significant quantities of unignited fuel can spread rapidly from leaking valves, flanges, cracked pipes, overfill relief systems, and routine maintenance, threatening personnel and plant safety. Serious incident escalation results from ignition of these flammable vapours.

As a further innovative development of the Angus Fixed Medium Expansion (MEX) Bund Purer range, these

semi-fixed units offer the flexibility of a "portable" approach. Following set up, personnel can then retreat to a safe area during operations.

Although primarily designed for vapour suppression of unignited spills and hazardous chemicals they can also be highly effective for fire protection applications.

These MEX pourers are also suited to many other applications requiring large volumes of free flowing foam eg. process areas, road traffic accidents, warehousing and finished goods storage protection.

These "Anderson" semi-fixed MEX Pourers represent an efficient and cost effective way of controlling risks with maximum flexibility. Their high performance design produces a free-flowing and stable foam blanket extinguishing fire and cooling vulnerable pipework minimising the risk of potential rupture.

The Angus semi-fixed range comprises three lightweight, compact and robust units. Foam solution flows range from 465 - 1970 litres per minute at inlet pressures of 1.5 to 3 bar.g. Operation at such low pressure minimises pumping capacities and water requirements, ensuring a cost effective system. A pressure gauge is incorporated to ensure the correct operating pressures are achieved.

These units are particularly effective when used with Angus fluoroprotein and film forming fluoroprotein foam concentrates (eg FP70 and Alco seal). The cohesive nature of FP/FFFP foams also minimises the effects of wind.

Each unit produces a large volume of free flowing stable MEX foam, providing rapid coverage of the banded area. Such gentle foam application minimises contamination of the foam by the fuel.

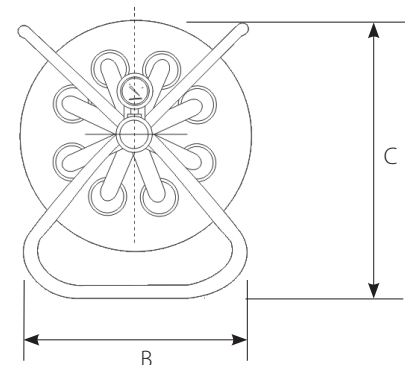
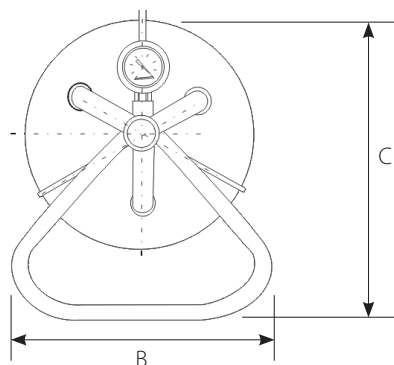
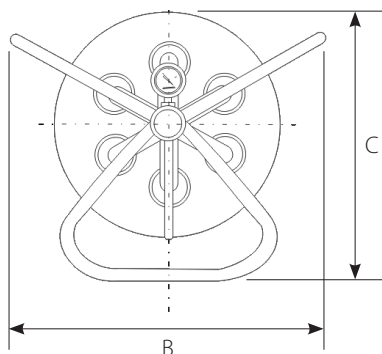
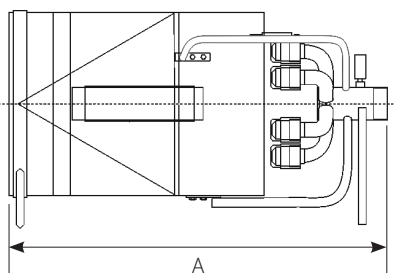

Anderson Mex Pourers

The Semi-Fixed Solution to Bund Protection

SPECIFICATION		MEX 600 SF	MEX 1200 SF	MEX 1800 SF
Nozzle Quantity		3	6	9
Dimensions	A (mm)	635	867	965
	B (mm)	320	530	524
	C (mm)	405	500	620
Inlet Connection		2" BSP Taper	2½" BSP Taper	3" BSP Taper
Materials	Pipework Spider	316 Stainless Steel		
	Nozzles	Brass/Gunmetal Natural Finish		
	Pourer Tube	316 Stainless Steel		
	Internals	316 Stainless Steel		
	Screws, Nuts, Washers	Stainless Steel		
Approximate Weight		9 Kg	17 Kg	25.5 Kg

PERFORMANCE DATA (Typical)		MEX 600 SF	MEX 1200 SF	MEX 1800 SF
K Factor*		380	759	1138
Operating Pressure Range			1.5 - 3 bar.g.	
Optimum Flow Rate @ 2.5 bar.g. Inlet Pressure		600 litres/min	1200 litres/min	1800 litres/min
Typical Expansion Ratio (using FP70 @ 3%)			35 - 50:1 @ 2.5 bar.g.	
Typical Foam Output @ 2.5 bar.g. (using FP70 @ 3%)		24 m ³ /min	48 m ³ /min	72 m ³ /min

* Flow (litre/min) = K P where P = pressure in bar.g.

INTERNATIONAL SALES

Angus Fire Ltd

Angus House, Haddenham Business Park,
Pegasus Way, Haddenham, Aylesbury, HP17 8LB, UK
Tel: +44 (0)1844 293600 • Fax: +44 (0)1844 293664

UK SALES

Angus Fire Ltd

Station Road, Bentham, Lancaster, LA2 7NA, UK
Tel: +44 (0)1524 264000 • Fax: +44 (0)1524 264180

Angus Fire operates a continuous programme of product development. The right is therefore reserved to modify any specification without prior notice and Angus Fire should be contacted to ensure that the current issues of all technical data sheets are used.

© Angus Fire
5109/4 05.16